



Compressed air powered balancer ezzFLOWpneumatic

The areas of application of the ezzFLOWpneumatic are the provision of components and the assembly of machines, apparatus and vehicles. In addition, in many other, especially repetitive handling tasks.

The ezzFLOWpneumatic works with compressed air and is a simple solution for many handling tasks.

All variants of the ezzFLOWpneumatic are equipped with optimized gripping systems for the task at hand.

Like all Best Handling Technology products, the ezzFLOWpneumatic can be equipped with a quick and easy-to-use tool change interface.

Load capacity: up to 350 kg

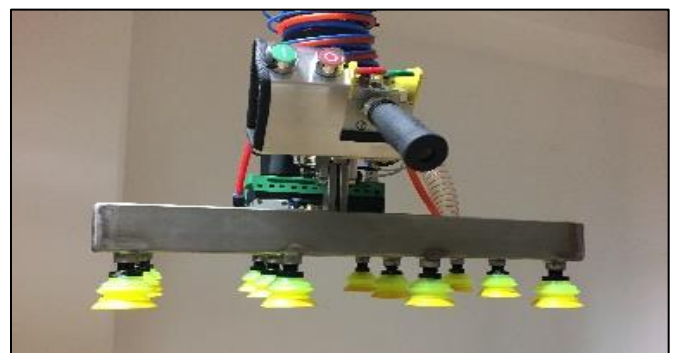



compressed air supply
crane system **ezzLINKmobil**
Mobile pillar jib crane with jib
(here in stainless steel)

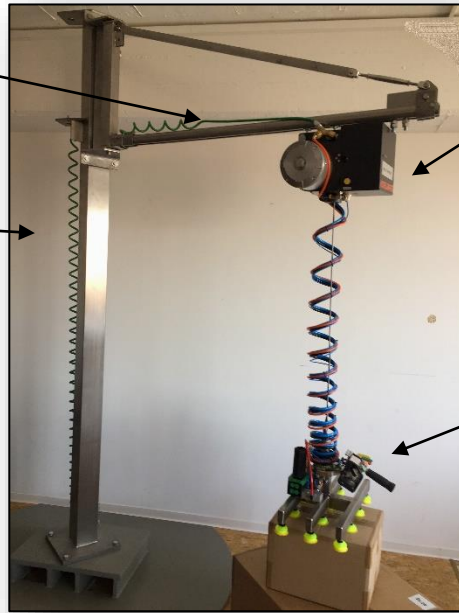

ezzFLOWpneumatic

gripper

Possible uses:

- Automotive, component, assembly assembly
- Loading of machine tools
- Handling of sensitive components
- Assembly aid for motors, gears, clutches, etc.
- Tool change

Crane system ezzLINK

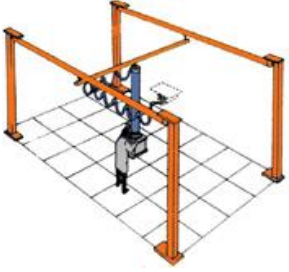
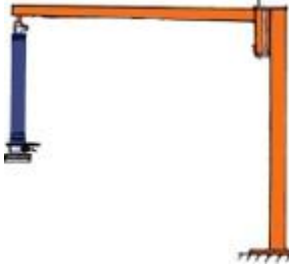
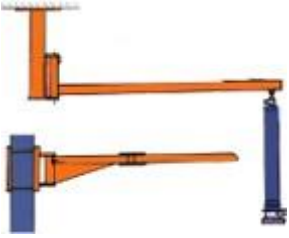
		
'H' version - covers large work areas. Mounted on pillars fixed to the ground or on existing ceiling structures.	Compact jib pillar crane. Ideal for low room heights. Range: up to 8 m	Wall or ceiling mounted with Boom or articulated arm. Range: up to 8 m

